

Researching Architectural Salvage through Experiential Education

Carey Clouse, AIA

UMass Amherst, Amherst, MA

ABSTRACT: In the streets of post-Katrina New Orleans, it was trash heaps, rather than signage, that offered the promise of a homeowner's return. Street-side mountains of soggy sheetrock, worn-out flooring and old windows provided a visual testament of rebuilding efforts inside; these piles of architectural debris framing gutted houses on almost every block. Such material waste regularly accompanies standard construction practices, where the yardstick of progress measures the number of dumpsters filled, and transformation implies resource depletion.

This perverse line of thinking was called into question by one team of architecture students at Tulane University, who in the midst of the post-Katrina rebuilding of New Orleans, sought to illuminate demolition excesses and the untapped potential inherent to such processes. Their efforts to identify the type and scope of this material waste led to extensive field-based data collection, material cataloging and resource mapping. Once they had completed this exhaustive product index, the design team produced an alternative concept of one such trash heap, demonstrating the productive capacity of design thinking and the value of direct action in the face of wasteful rebuilding practices.

KEYWORDS: Pedagogy, Design/Build, New Orleans, Rebuilding, Advocacy

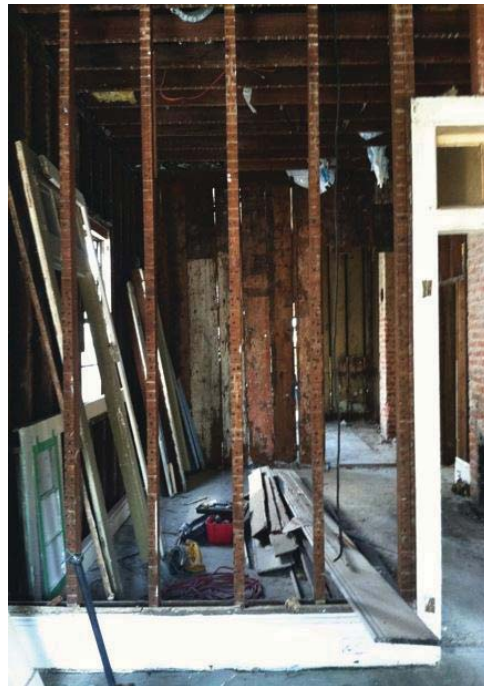

Figure 1: Outside a building in New Orleans, material slated for the landfill. Source: (Clouse 2011)

Figure 2: A gutted house in New Orleans, ready for reconstruction. Source: (Clouse 2011)

1.0 Experiential Education and Design Service

Post-Katrina New Orleans' waste-stream-made-visible provided a call to action; street-side debris became a ripe resource for both student-led research and their own subsequent creative design intervention. By framing this waste problem as a design opportunity, the pedagogical techniques of community service *and* rigorous data collection became a vehicle for student learning. In doing so, this two-pronged experiential approach also helped students to make the connection between design service and environmental awareness.

This architectural salvage research highlights the advantages of bridging conventional design teaching from established educational paradigms and the woolly, irregular and unexpected lessons presented in the real world. This pedagogical approach narrows the gap between thinking and doing, reinforcing accepted design principles through hands-on innovation and experimentation.

This model of experiential education has been articulated by deep-rooted educators such as Aristotle,¹ and canonized more recently into Western pedagogy with the work of John Dewey, Kurt Lewin, Jean Piaget, and Paolo Freire. The assertion that learning happens more effectively through instructive experiences (reflection by doing) fits neatly into architectural praxis. This disciplinary suitability was demonstrated in New Orleans, where design students developed their learning about environmental stewardship, material constraints, fabrication, product flows, community engagement and a host of other issues by responding to a real-world design challenge.

While experiential education takes many forms, this project was contained within the husk of research and inquiry; namely as an examination of existing conditions. Only once this survey and mapping was completed did the students probe deeper into their role as design-activists. Design-by-doing pairs well with critical interrogation and reflection, and in the case of this architectural salvage analysis, students balanced hands-on fieldwork with classroom research, material exploration with readings and references. The focus of this study was a real-world problem, and in digging into this issue, students honed extant skills while becoming exposed to new information.

2.0 Background

In an effort to understand the impact of the enormous construction debris caches that materialized in the wake of Hurricane Katrina, a small team of students from Tulane's School of Architecture took to the streets to collect data. Together they worked to inventory products, categorize material properties, and map subsequent flows. They began by questioning the characteristics of abandoned building materials, targeting one trash pile along a street in a flooded mid-city neighborhood. Initially, they picked apart the heap of debris to determine the amount, weight, volume and type of refuse generated by a typical freshly-gutted house.



Figure 3: The trash heap, typical in post-Katrina New Orleans, studied by students. Source: (Clouse 2010)

Although the home's unbuilders (or rebuilders) had intentionally rejected this pile of materials, the majority of this deconstruction waste was in fact reusable. Fine architectural fixtures of the last century---decadent moldings and solid true wood, windows, doors, cabinetry, and tongue and groove flooring---have value born out of the fact that they simply are not available today. While perhaps not suitable for their original house host, these items can be directly reused in another location or even upcycled to a different, improved use.

Once these architectural gems have been salvaged, the rest of the waste pile qualifies for a more traditional recycling route. Scrap wood, metals and glass could be separated and re-constructed. Organic matter would make rich compost. Toxic materials, such as asbestos, paints or poisons, might get quarantined in safe containers.



Figure 4: One typical house in New Orleans, awaiting renovation. Source: (Clouse 2011)

Yet despite the more than 22 million tons of construction and demolition debris generated by Hurricane Katrina in 2005, (Ardani 2007) material salvage operations served only a small fraction of the rebuilding community.² In New Orleans, salvaged building materials find new life only through a small number of enterprising organizations that rely entirely upon independent coordination with contractors and homeowners.³ For every house that benefits from the selective deconstruction offered by these salvage operations, hundreds of other houses end up in the landfill.



Figure 5: New Orleans' primary landfill, which abuts the Mississippi River watershed. Source: (Clouse 2011)

These houses add up. The Greater New Orleans Community Data Center has estimated that 134,000 houses, occupied at the time of Katrina, were significantly damaged due to the storm and are undergoing renovation.(Plyer 2012, 1) The contents of these buildings have become a heavy burden for landfills to

shoulder, which are, not surprisingly, bursting at the seams. In the months after Katrina made landfall, the City of New Orleans was pressed to reopen geriatric garbage pits to accommodate this influx of trash, to the detriment of surrounding communities and ecosystems.

While this massive resource-dumping may finally have been staunched by the gift of time in New Orleans, the dearth of salvaged building materials undoubtedly caused longer gestation periods for rebuilders. Students from the architectural salvage research team wanted to highlight this unfortunate loss. Believing that any city in today's resource-scarce environment, rebuilding or not, would benefit from more progressive material salvage practices, they saw this research as a form of public outreach, improving communication about architectural salvage.



Figure 6: A process board developed by students. Source: (Keller 2009)

3.0 Methodology

1. Representation as Research

The first phase of the architectural salvage research project employed field identification and subsequently, representational modes of architectural inquiry. The mapping and diagramming that was used to both index this trash and identify material salvage operations constituted new and useful visual references for others to resource. Coupled with Alan Weisman's projections for waste, (Weisman 2008) students began to parse both the type and effect of each product. In deciphering the pile of debris, students learned about the qualities of those materials, including where they came from and would be going next.

As one might expect in peeling back the layers of an entire house, the quality, weight, volume and properties of each of these materials varied considerably. Contents ranged from the predictable to the bizarre: one set of drawers, two crutches, two sets of suspenders, one ball of twine, one bag of rusted nails and screws, one ball of fishing line, 500 linear feet of tongue and groove pine flooring, one box of glassware, two mirrors, several lamps, one fluorescent light, one singing big mouth bass trophy, eight strands of Mardi Gras beads, thirty-six hangers, one pair of lace curtains, one ceramic paperweight, three chairs, one bicycle, one bag, 150 linear feet of miscellaneous wood scraps, two solid wood doors, and two brooms. The students approached this mountain of material as a modern-day midden, dissecting the bits and cataloguing each piece accordingly.

During this representational phase, these material findings were then translated into a material resource map, material quality lists, and a photographic essay that helped to tell the story of the pile's contents. In doing so, the students capably illustrated their findings, rendering the information accessible to the public. At this stage one of the most useful drawings emerged: a map depicting the recycling stations for architectural salvage in New Orleans for citizens to reference.



Figure 7: A resource map made by students for community use. Source: (Keller 2009)

II. Material Explorations

While the goal of this research was primarily to highlight the amount of trash generated by post-Katrina house gutting, a secondary intention was born out of the process itself. In parsing the data for the first phase, students stumbled upon appealing opportunities for formal design exploration. The project foregrounds creative re-use strategies for construction debris, which ultimately re-framed this research through the lens of material explorations (methods) and design|build. (Bonnemaïson and Eisenbach 2009)

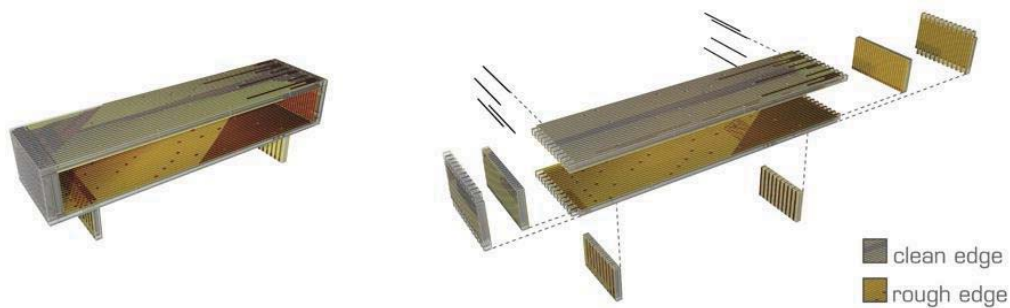

Figure 8: Design drawings for the student-fabricated furniture piece. Source: (Keller 2009)

After considering the possibilities revealed by each of the materials they uncovered, the students developed a design for a productive, upcycled physical object. In this case, it was a table that would illustrate the new potential embedded within old woodwork. This design was built entirely out of the materials found in the catalogued trash pile.



Figure 9: The end table on display for the community. Source: (Clouse 2011)

III. Community Engagement

This research culminated in a community-engaged design response. The student team identified two forums for their work, targeting community members who might be involved in the rebuilding effort in New Orleans. For a presentation at the *Focus The Nation Conference*, and later, an exhibit called *Salvations*, this team designed a poster documenting their process, a physical display (including the furniture piece) and propaganda that could be disseminated to challenge waste memes. In addition to highlighting the architectural salvage opportunities in post-Katrina New Orleans, the team also demonstrated a feasible strategy for upcycling material waste. The goal of this research thus changed; evolving from merely highlighting the amount and quality of trash generated by post-Katrina house-gutting to a commentary on the lack of a comprehensive building recycling program in New Orleans, inspiring ideas for direct action around the topic of material salvage.

4.0 Community Outreach

While not explicitly a community-engaged design process, the work of these students helped to illuminate the inherent opportunities for material salvage, ultimately inviting the public to take action. Their expressive diagrammatic design contributions, furniture, categorized materials, and maps of recycling yards were shared with the community at two public events. The team made this research available online, and using paper and beeswax also crafted hundreds of refrigerator magnets to serve as tactile reminders about architectural salvage, which were distributed for free to event attendees.

The challenging-but-necessary terrain of community-based design work makes academic exposure to the subject all the more critical. Mark Robbins contends that “it is our obligation as educators and architects to reveal the stunning complexity and nuances of community-based work,”(Pearson 2002, 2) whether through the lens of experiential education or by some other means. In the case of the material salvage research project, the simple act of *doing the work* had the effect of “simultaneously educating students in the realities of public service and educating communities about the value of design in achieving a positive future.”(Pearson 2002, 13)

5.0 Lessons Learned

Tulane School of Architecture’s student team found value in the garbage they inventoried, which led them to the conclusion that scrappers would benefit from a comprehensive building material recycling program initiated in New Orleans. This system could divert waste from overwhelmed landfills while providing the rebuilding effort with a plentiful source of high quality building materials. This kind of program would save energy and natural resources, create green jobs, reduce Hurricane Katrina’s carbon footprint, improve the quality and diversity of the city’s building stock, preserve the historic character of this city, and contribute to a smarter local economy.

For educators, this project demonstrates an effective model for research through experiential education, community engagement, hands-on building, and thorough material investigation. The architectural salvage research project, framed in terms of both research and advocacy, offers up a new model for architectural engagement. The deep field-based investigation of an issue, coupled with a more public

and accessible sharing of findings, provides unique learning opportunities routinely neglected in a more traditional design studio curriculum. In researching material salvage through the context of a real-world problem, students were able to draw their own conclusions about the role of design in sustainable urbanism, community engagement and opportunistic place-based action.

In participating in a hands-on, community-based research project, students realized that engaged designers can become "key catalysts in shaping a positive future." (Pearson 2002, 5) This design activism demands professional re-framing, according to Patrick Coulombel, whose *Open Letter to Architects, Engineers, and Urbanists*, declared that "the profession of architecture must be reinvented to embrace a commitment to solving these fundamental problems of civil life." (Coulombel 2011, 291) Indeed, this type of design research project challenges students to develop an ethical attitude towards service-based practice that may mature and endure.

In the city of New Orleans, a man-made disaster was responsible for revealing the latent potential of public garbage flows. However, this issue—the problem of material waste and diminishing resources—transcends the geographic boundaries of the Crescent City. This project provides a proposition: that an inventory of endangered architectural gems, developed across regions and activated independently of crisis, could scale up to incite widespread environmental change.



Figure 10: A dumpster outside a typical gutted house in New Orleans. Source: (Clouse 2011)

ACKNOWLEDGEMENTS

Thanks to students Greg Hayslett and Michael Keller, The Tulane City Center, Tulane School of Architecture and The Green Project.

REFERENCES

- Ardani, Kristen. 2007. "Waste-to-Energy Technology: A Solution to New Orleans' Debris Burden." *Review of Policy Research* 24 (7) (September). <http://trid.trb.org/view.aspx?id=850970>.
- Bonnemaïson, Sarah, and Ronit Eisenbach. 2009. *Installations By Architects: Experiments in Building and Design*. 1st ed. Princeton Architectural Press.
- Brillembourg, Alfredo, Hubert Klumpner, and Patrick Coulombel. 2011. *Beyond Shelter: Architecture and Human Dignity*. Ed. Marie Aquilino. Metropolis Books.
- Pearson, Jason. 2002. *University/Community Design Partnerships*. 1st ed. Princeton Architectural Press.
- Plyer, Alison. 2012. "Facts for Features," Community Data Center, accessed 02.15.2013 at: <http://www.gnocdc.org/Factsforfeatures/HurricaneKatrinaImpact/index.html>
- Weisman, Alan. 2008. *The World Without Us*. Reprint. Picador.

ENDNOTES

¹ Aristotle's oft-quoted experiential education view: "For the things we have to learn before we can do them, we learn by doing them."

² *The Green Project* has deconstructed several dozen houses through contracts, while *Mercy Corps* has finished at least twenty.

³ *Mercy Corps*, *The Green Project*, *Habitat for Humanity* and *Rebuilding Together* are some of the organizations that specialize in building material salvage in New Orleans.